

## **FORMAT OF PRESENTATION Nomadic Circus VR (theaters / exhibition halls)**

**BUILT UP** : 3 hours

**BUILT DOWN** : 2 hours

Presence of one technician of the structure (built up 3 hours & built down 2 hours)

### **GENERAL INFORMATIONS**

The experience is adaptable according to the performance venue ; both in its time of installation ( scenography, light design) and audience capacity . We receive between 10 to 20 people every 45 minutes. The performance is ongoing and we present up to 8 times a day. (possibility of add supplementaire sessions (up to 12 per day for an additional price).

*We kindly ask the organiser to send us pictures and exact dimensions of the performance venue minimum 1 month in advance to facilitate the installation process.*

### **STAGE INFORMATIONS**

- Ideally a flat, leveled floor
- Indoors (room / studio), in a low light and preferably quiet space or possibility to create a feeling of "black box".

Stage dimensions required :

For an audience of 10 : 6m x 6m

For an audience of 15 : 7m x7m

For an audience of 20 : 8m x 8 m

### **ADDITIONAL DEMAND**

- Please check that you can provide a 4G network on site
- One person from the organization to receive the public before each session and help with disinfection of VR headset between each session.

## STAGE EQUIPMENT

10 - 20 rotating chairs (360°)\*

2 fans on stand\*

2 large tables for VR headsets (75cmx160cm)

1 small table (40x80)\*

## LIGHT

6 PAR 64 cp62 1Kw on floor plates / OR 6 fresnels 1Kw

*Filters*

3 x L195 (or L119 / L197)

3x L204 (or L205 / L206)

## SOUND

2 speakers on stands (broadcasting from a computer)

## CABLING

12 extension cords of min 5m

4 extension cords of 2m

4 multiplugs with 2 sockets

4 multiplugs with 3 sockets

3 multiplugs with 4 sockets

7 non dimmable 16A power sockets

**\* provided by the company if travelling by truck.**

## STAGE PLAN

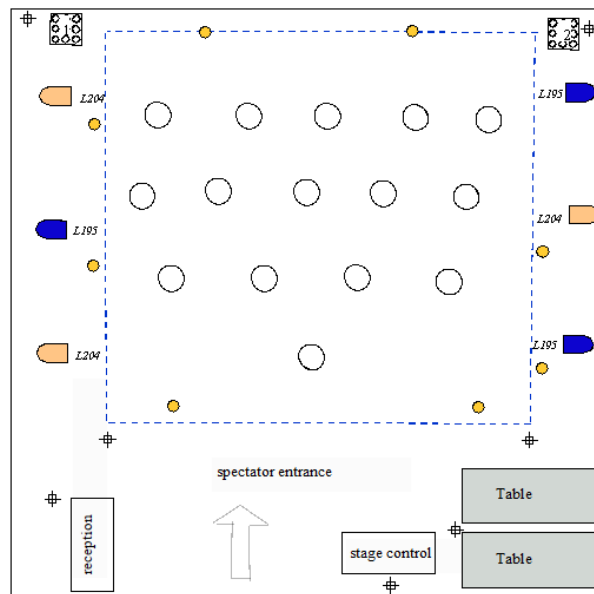
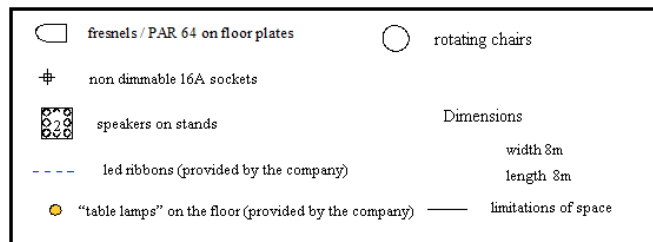

## EXAMPLES OF THIS INSTALLATION



Imaginarium | Festival Internacional de Teatro de Rua (PT)



CIAM | Festival Jours et nuits de cirques



International Biennial of Circus Arts



CircoTech | La Grainerie



Ateliers Médicis | Clichy-sous-bois



## FHEEL CONCEPTS TEAM

1 artist & 1 technician

## SCHEDULE

Team arrival : D-1 if travelling more than 3 hours (from Toulouse). Less than 3 hours of travel : arrival D Day.

Team departure : 3 hours after the last session.

## TOUR CONDITIONS

- We are asking that the stage have a temperate temperature not exceeding 27°C. The virtual headsets will be stored there, hence the thermal condition.
- A dressing room and a small catering (biscuits, dried fruit, fresh fruit, water, fruit juice, coffee, tea, etc.) must be made available to the artistic and technical team through the day.

## COSTS PAID BY THE ORGANISER

- Round trip travel by car from Toulouse (kilometric allowances of € 0,595/km) / or travel by train/ plane (2 suitcases of 33 kg and 2-3 suitcases of 23 kg) • Accommodation on site (2 single rooms) • Meals on the way and meals on site.

*If you have any question, contact :  
GRENIER Marjolaine  
technique.fheelconcepts@gmail.com  
0033 6 75 98 62 52*

